

# DX Accessory

## AMC+ Amplitude Modulation Companding Plus

Revision D  
888-2509-003

Harris Broadcast is an independent company not affiliated with Harris Corporation.

**Deliver the moment.**



**TECHNICAL MANUAL**  
**888-2509-003**  
**AMC+**  
***Amplitude Modulation Companding Plus***

**Harris Broadcast**  
9800 S Meridian Blvd, Ste 300  
Englewood, CO 80112 U.S.A

Copyright ©2013, Harris Broadcast. Proprietary and Confidential.

This document and its contents are considered proprietary and confidential by Harris Broadcast. This publication, or any part thereof, may not be reproduced in any form, by any method, for any purpose, or in any language other than English without the written consent of Harris Broadcast. A reasonable number of copies of this document may be made for internal use only. All others uses are illegal.

This publication is designed to assist in the use of the product as it exists on the date of publication of this manual, and may not reflect the product at the current time or an unknown time in the future. This publication does not in any way warrant description accuracy or guarantee the use for the product to which it refers.

Harris Broadcast reserves the right, without notice to make such changes in equipment, design, specifications, components, or documentation as progress may warrant to improve the performance of the product.

Harris Broadcast is an independent company not affiliated with Harris Corporation.

### **Trademarks**

Flexiva and Maxiva are trademarks of Harris Broadcast or its subsidiaries.

Microsoft® and Windows® are registered trademarks of Microsoft Corporation.

All other trademarks and trade names are the property of their respective companies.

### **Support Contact Information**

For domestic and international support contact information, See:

- Support Contacts: <http://harrisbroadcast.com/support>
- eCustomer Portal: <http://support.harrisbroadcast.com>

**WARNING: Disconnect primary power prior to servicing.**

## Manual Revision History

### **AMC+ Amplitude Modulation Companding Technical Manual**

| <b>REV.</b> | <b>DATE</b> | <b>ECN</b> | <b>Pages Affected / Description</b>           |
|-------------|-------------|------------|-----------------------------------------------|
| Preliminary |             |            | Created                                       |
| 0           |             |            | Review Copy to Service, Engineering, & Safety |
| A           |             |            | Release Rev. A                                |
| A1          | 8/2011      |            | Revised to include AMC+                       |
| B           | 24Oct2011   | P51317     | Revised Title Page, MRH-1 and Section 4.2.6   |
| C           | 20Jul2012   | P53390     | Revised Title Page, MRH-1 & Pages 2-10, 2-12  |
| D           | 03Oct2013   | P55694     | Revised Title Page, MRH-1 & Pages 2-5         |
|             |             |            |                                               |

**MRH-1**

**WARNING: Disconnect primary power prior to servicing.**

## Technical Assistance

Technical and troubleshooting assistance for Harris Broadcast products is available from the field service department during normal business hours 8:00AM to 5:00PM CST.

Telephone +1-217-222-8200, FAX +1-217-221-7086, email [tsupport@harrisbroadcast.com](mailto:tsupport@harrisbroadcast.com).

**Emergency service is available 24 hours a day, seven days a week, by telephone only.**

Online assistance, including technical manuals, software downloads, and service bulletins, is available at <http://www.harrisbroadcast.com/servicesandsupport/default.asp>.

Address written correspondence to Field Service Dept.  
Harris Broadcast  
P.O. Box 4290  
Quincy, IL 62305-4290, USA.

For global service contact information, visit: <http://www.harrisbroadcast.com/contactus>.

**NOTE:** For all service and parts correspondence, please provide the sales order number, as well as the serial number for the transmitter or part in question. Record those numbers here:

\_\_\_\_\_ / \_\_\_\_\_

Provide these numbers for any written request, or have these numbers ready in the event you choose to call regarding any service or parts requests. For warranty claims it will be required. For out of warranty products, this will help us identify what hardware shipped.

## Replaceable Parts Service

The service parts department is available from 7:00AM to 5:00 PM CST Monday - Friday, and 8:00AM to 12:00PM CST on Saturday.

Telephone +1-217-221-7500 or email [servicepartsreq@harrisbroadcast.com](mailto:servicepartsreq@harrisbroadcast.com).

**Emergency parts are available 24 hours a day, seven days a week, by telephone only.**

## Unpacking

Carefully unpack the equipment and perform a visual inspection to determine if any damage was incurred during shipment. Retain the shipping materials until it has been verified that all equipment has been received undamaged. Locate and retain all packing check lists. Use the packing check list to help locate and identify any components or assemblies which are removed for shipping and must be reinstalled. Also remove any shipping supports, straps, and packing materials prior to initial turn on.

## Returns And Exchanges

No equipment can be returned unless written approval and a return authorization is received from Harris Broadcast. Special shipping instructions and coding will be provided to assure proper handling. Complete details regarding circumstances and reasons for return are to be included in the request for return. Custom equipment or special order equipment is not returnable. In those instances where return or exchange of equipment is at the request of the customer, or convenience of the customer, a restocking fee will be charged. All returns will be sent freight prepaid and properly insured by the customer. When communicating with Harris Broadcast, specify the Harris Broadcast order number or invoice number.

**WARNING: Disconnect primary power prior to servicing.**







**⚠ WARNING:**  
*THE CURRENTS AND VOLTAGES IN THIS EQUIPMENT ARE DANGEROUS. PERSONNEL MUST AT ALL TIMES OBSERVE SAFETY WARNINGS, INSTRUCTIONS AND REGULATIONS.*

This manual is intended as a general guide for trained and qualified personnel who are aware of the dangers inherent in handling potentially hazardous electrical/electronic circuits. It is not intended to contain a complete statement of all safety precautions which should be observed by personnel in using this or other electronic equipment.

The installation, operation, maintenance and service of this equipment involves risks both to personnel and equipment, and must be performed only by qualified personnel exercising due care. Harris Broadcast shall not be responsible for injury or damage resulting from improper procedures or from the use of improperly trained or inexperienced personnel performing such tasks. During installation and operation of this equipment, local building codes and fire protection standards must be observed.

The following National Fire Protection Association (NFPA) standards are recommended as reference:

- Automatic Fire Detectors, No. 72E
- Installation, Maintenance, and Use of Portable Fire Extinguishers, No. 10
- Halogenated Fire Extinguishing Agent Systems, No. 12A

**⚠ WARNING:**  
*ALWAYS DISCONNECT POWER BEFORE OPENING COVERS, DOORS, ENCLOSURES, GATES, PANELS OR SHIELDS. ALWAYS USE GROUNDING STICKS AND SHORT OUT HIGH VOLTAGE POINTS BEFORE SERVICING. NEVER MAKE INTERNAL ADJUSTMENTS, PERFORM MAINTENANCE OR SERVICE WHEN ALONE OR WHEN FATIGUED.*

Do not remove, short-circuit or tamper with interlock switches on access covers, doors, enclosures, gates, panels or shields. Keep away from live circuits, know your equipment and don't take chances.

**⚠ WARNING:**  
*IN CASE OF EMERGENCY ENSURE THAT POWER HAS BEEN DISCONNECTED.*  
*IF OIL FILLED OR ELECTROLYTIC CAPACITORS ARE UTILIZED IN YOUR EQUIPMENT, AND IF A LEAK OR BULGE IS APPARENT ON THE CAPACITOR CASE WHEN THE UNIT IS OPENED FOR SERVICE OR MAINTENANCE, ALLOW THE UNIT TO COOL DOWN BEFORE ATTEMPTING TO REMOVE THE DEFECTIVE CAPACITOR. DO NOT ATTEMPT TO SERVICE A DEFECTIVE CAPACITOR WHILE IT IS HOT DUE TO THE POSSIBILITY OF A CASE RUPTURE AND SUBSEQUENT INJURY.*

**WARNING: Disconnect primary power prior to servicing.**

## TREATMENT OF ELECTRICAL SHOCK

1. IF VICTIM IS NOT RESPONSIVE FOLLOW THE A-B-CS OF BASIC LIFE SUPPORT.

PLACE VICTIM FLAT ON HIS BACK ON A HARD SURFACE

### **(A) AIRWAY**

IF UNCONSCIOUS,  
OPEN AIRWAY

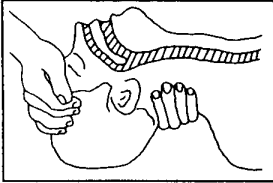

LIFT UP NECK  
PUSH FOREHEAD BACK  
CLEAR OUT MOUTH IF NECESSARY  
OBSERVE FOR BREATHING

CHECK  
CAROTID PULSE

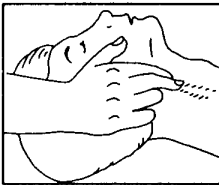

IF PULSE ABSENT,  
BEGIN ARTIFICIAL  
CIRCULATION

### **(B) BREATHING**

IF NOT BREATHING,  
BEGIN ARTIFICIAL BREATHING

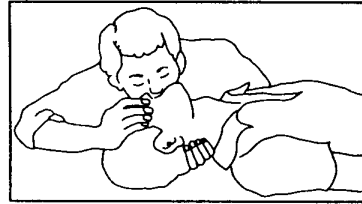

TILT HEAD  
PINCH NOSTRILS  
MAKE AIRTIGHT SEAL  
4 QUICK FULL BREATHS  
REMEMBER MOUTH TO MOUTH  
RESUSCITATION MUST BE  
COMMENCED AS SOON AS POSSIBLE

### **(C) CIRCULATION**

DEPRESS STERNUM 1 1/2 TO 2 INCHES

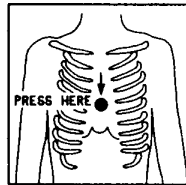

APPROX. RATE  
OF COMPRESSIONS { ONE RESCUER  
--80 PER MINUTE { 15 COMPRESSIONS  
2 QUICK BREATHS

APPROX. RATE  
OF COMPRESSIONS { TWO RESCUERS  
--60 PER MINUTE { 5 COMPRESSIONS  
1 BREATH

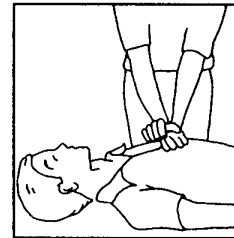

NOTE: DO NOT INTERRUPT RHYTHM OF COMPRESSIONS  
WHEN SECOND PERSON IS GIVING BREATH

CALL FOR MEDICAL ASSISTANCE AS SOON AS POSSIBLE.

2. IF VICTIM IS RESPONSIVE.

- A. KEEP THEM WARM
- B. KEEP THEM AS QUIET AS POSSIBLE
- C. LOOSEN THEIR CLOTHING
- D. A RECLINING POSITION IS RECOMMENDED

**WARNING: Disconnect primary power prior to servicing.**

## FIRST-AID

Personnel engaged in the installation, operation, maintenance or servicing of this equipment are urged to become familiar with first-aid theory and practices. The following information is not intended to be complete first-aid procedures, it is a brief and is only to be used as a reference. It is the duty of all personnel using the equipment to be prepared to give adequate Emergency First Aid and there by prevent avoidable loss of life.

### Treatment of Electrical Burns

1. Extensive burned and broken skin
  - a. Cover area with clean sheet or cloth. (Cleanest available cloth article.)
  - b. Do not break blisters, remove tissue, remove adhered particles of clothing, or apply any salve or ointment.
  - c. Treat victim for shock as required.
  - d. Arrange transportation to a hospital as quickly as possible.
  - e. If arms or legs are affected keep them elevated.

#### NOTE:

If medical help will not be available within an hour and the victim is conscious and not vomiting, give him a weak solution of salt and soda: 1 level teaspoonful of salt and 1/2 level teaspoonful of baking soda to each quart of water (neither hot or cold). Allow victim to sip slowly about 4 ounces (a half of glass) over a period of 15 minutes. Discontinue fluid if vomiting occurs. (Do not give alcohol.)

2. Less severe burns - (1st & 2nd degree)
  - a. Apply cool (not ice cold) compresses using the cleanest available cloth article.
  - b. Do not break blisters, remove tissue, remove adhered particles of clothing, or apply salve or ointment.
  - c. Apply clean dry dressing if necessary.
  - d. Treat victim for shock as required.
  - e. Arrange transportation to a hospital as quickly as possible.
  - f. If arms or legs are affected keep them elevated.

#### REFERENCE:

ILLINOIS HEART ASSOCIATION  
AMERICAN RED CROSS STANDARD FIRST AID AND PERSONAL SAFETY MANUAL  
(SECOND EDITION)

**WARNING: Disconnect primary power prior to servicing.**

## Guide to Using Parts List Information

The Replaceable Parts List Index portrays a tree structure with the major items being left most in the index. The example below shows the Transmitter as the highest item in the tree structure. If you were to look at the bill of materials table for the Transmitter you would find the Control Cabinet, the PA Cabinet, and the Output Cabinet. In the Replaceable Parts List Index the Control Cabinet, PA Cabinet, and Output Cabinet show up one indentation level below the Transmitter and implies that they are used in the Transmitter. The Controller Board is indented one level below the Control Cabinet so it will show up in the bill of material for the Control Cabinet. The tree structure of this same index is shown to the right of the table and shows indentation level versus tree structure level.

Example of Replaceable Parts List Index and equivalent tree structure:

| Replaceable Parts List Index  | Part Number  | Page |
|-------------------------------|--------------|------|
| Table 7-1. Transmitter        | 995 9283 001 | 7-2  |
| Table 7-2. Control Cabinet    | 981 9244 002 | 7-3  |
| Table 7-3. Controller Board   | 901 8344 002 | 7-6  |
| Table 7-4. PA Cabinet         | 981 9400 002 | 7-7  |
| Table 7-5. PA Amplifier       | 971 7894 002 | 7-9  |
| Table 7-6. PA Amplifier Board | 901 7904 002 | 7-10 |
| Table 7-7. Output Cabinet     | 981 9450 001 | 7-12 |

```

graph TD
    Transmitter["Transmitter  
995 9283 001"] --> ControlCabinet["Control Cabinet  
981 9244 002"]
    Transmitter --> PACabinet["PA Cabinet  
981 9400 002"]
    Transmitter --> OutputCabinet["Output Cabinet  
981 9450 001"]
    ControlCabinet --> ControllerBoard["Controller Board  
901 8344 002"]
    PACabinet --> PAAmplifier["PA Amplifier  
971 7894 002"]
    PAAmplifier --> PAAmplifierBoard["PA Amplifier Board  
901 7904 002"]
  
```

The part number of the item is shown to the right of the description as is the page in the manual where the bill for that part number starts. Inside the actual tables, four main headings are used:

- Table #-#. ITEM NAME - PART NUMBER - this line gives the information that corresponds to the Replaceable Parts List Index entry;
- PART NUMBER column gives the ten digit Harris Broadcast part number (usually in ascending order);
- DESCRIPTION column gives a 25 character or less description of the part number;
- REF. SYMBOLS/EXPLANATIONS column 1) gives the reference designators for the item (i.e., C001, R102, etc.) that corresponds to the number found in the schematics (C001 in a bill of material is equivalent to C1 on the schematic) or 2) gives added information or further explanation (i.e., "Used for 208V operation only," or "Used for HT 10LS only," etc.).

**NOTE: Inside the individual tables some standard conventions are used:**

- A # symbol in front of a component such as #C001 under the REF. SYMBOLS/EXPLANATIONS column means that this item is used on or with C001 and is not the actual part number for C001.
- In the ten digit part numbers, if the last three numbers are 000, the item is a part that has been purchased and has not manufactured or modified. If the last three numbers are other than 000, the item is either manufactured or is purchased from a vendor and modified for use in the Harris Broadcast product.
- The first three digits of the ten digit part number tell which family the part number belongs to - for example, all electrolytic (can) capacitors will be in the same family (524 xxxx 000). If an electrolytic (can) capacitor is found to have a 9xx xxxx xxx part number (a number outside of the normal family of numbers), it has probably been modified in some manner at the factory and will therefore show up farther down into the individual parts list (because each table is normally sorted in ascending order). Most Harris Broadcast made or modified assemblies will have 9xx xxxx xxx numbers associated with them.

The term "SEE HIGHER LEVEL BILL" in the description column implies that the reference designated part number will show up in a bill that is higher in the tree structure. This is often the case for components that may be frequency determinant or voltage determinant and are called out in a higher level bill structure that is more customer dependent than the bill at a lower level.

**WARNING: Disconnect primary power prior to servicing.**

# Table of Contents

---

## Section-1 Introduction

|                                    |     |
|------------------------------------|-----|
| Scope And Purpose . . . . .        | 1-1 |
| Equipment Description . . . . .    | 1-1 |
| AMC+ Concept . . . . .             | 1-1 |
| Graphical Representation . . . . . | 1-2 |
| Power Savings . . . . .            | 1-3 |
| Conclusion . . . . .               | 1-3 |
| Block Diagram . . . . .            | 1-3 |
| Specifications . . . . .           | 1-3 |
| Reduction Accuracy . . . . .       | 1-3 |
| Squarewave Overshoot . . . . .     | 1-3 |
| AMC+ Operation . . . . .           | 1-3 |
| Audio Input Level . . . . .        | 1-3 |
| Audio Input Impedance . . . . .    | 1-3 |
| Audio Input Connector . . . . .    | 1-3 |

## Section-2 Installation

|                                                         |     |
|---------------------------------------------------------|-----|
| Introduction . . . . .                                  | 2-1 |
| Returns And Exchanges . . . . .                         | 2-1 |
| Unpacking . . . . .                                     | 2-1 |
| Installation . . . . .                                  | 2-1 |
| Test Equipment Needed for Installation . . . . .        | 2-1 |
| Transmitter Configuration and Alignment . . . . .       | 2-2 |
| Mechanical Installation and Audio Connections . . . . . | 2-2 |
| Mount Resistors . . . . .                               | 2-2 |
| Mount AMC+ Board . . . . .                              | 2-2 |
| Make Audio, RF and Voltage Connections . . . . .        | 2-3 |
| Analog Input Board Modifications . . . . .              | 2-5 |
| Initial Settings After Installation . . . . .           | 2-5 |
| Select AMC+ Phase Delay (S3) . . . . .                  | 2-5 |
| AMC+ Setup for DX Transmitters . . . . .                | 2-6 |
| Initial Turn On . . . . .                               | 2-8 |
| AMC+ Verification . . . . .                             | 2-8 |

## Section 3 Operation

|                                   |     |
|-----------------------------------|-----|
| Introduction . . . . .            | 3-1 |
| Operation . . . . .               | 3-1 |
| AMC+ Bypass . . . . .             | 3-1 |
| AMC+ On . . . . .                 | 3-1 |
| Controls and Indicators . . . . . | 3-1 |

## Section-4 Theory

|                                         |     |
|-----------------------------------------|-----|
| Introduction . . . . .                  | 4-1 |
| AMC+ OFF Mode of Operation . . . . .    | 4-1 |
| AMC+ ON Mode of Operation . . . . .     | 4-1 |
| Detailed Circuit Description . . . . .  | 4-1 |
| Audio Input . . . . .                   | 4-1 |
| A/D Converter - Look Up Table . . . . . | 4-1 |
| D/A Converter . . . . .                 | 4-1 |
| Phase Delay . . . . .                   | 4-2 |
| Carrier Synchronization . . . . .       | 4-2 |
| Remote Control . . . . .                | 4-2 |
| Audio+DC Output Driver . . . . .        | 4-2 |
| Power Supplies . . . . .                | 4-2 |

## Section-5 Maintenance

|                                              |     |
|----------------------------------------------|-----|
| Introduction . . . . .                       | 5-1 |
| Purpose . . . . .                            | 5-1 |
| AMC+ Phase Delay (S3) . . . . .              | 5-1 |
| AMC+ Alignment for DX Transmitters . . . . . | 5-1 |
| AMC+ Verification Procedure . . . . .        | 5-1 |

## Section-6 Troubleshooting

|                                     |     |
|-------------------------------------|-----|
| Introduction . . . . .              | 6-1 |
| Troubleshooting Hierarchy . . . . . | 6-1 |
| Power Supplies . . . . .            | 6-1 |
| Carrier Sync . . . . .              | 6-1 |
| Jumper Settings . . . . .           | 6-1 |
| Audio Input/Output . . . . .        | 6-1 |
| ACC bypass mode . . . . .           | 6-1 |
| Component Table . . . . .           | 6-2 |

## Section 7 Parts List

|                      |     |
|----------------------|-----|
| Parts List . . . . . | 7-1 |
|----------------------|-----|

## **Table of Contents (Continued)**

---

# 1 Section-1 Introduction

---

## 1.1 Scope And Purpose

This technical manual contains the information necessary to install and maintain the AMC+ Amplitude Modulation Companding. The manual is conveniently divided into the following sections:

- SECTION I INTRODUCTION/SPECIFICATIONS. Provides general manual layout equipment description, block diagrams, description and specifications.
- SECTION II INSTALLATION/INITIAL TURN-ON. Provides detailed installation procedures and initial turn on instructions.
- SECTION III OPERATORS GUIDE. Provides a description of the normal operation of the unit using controls and indicators.
- SECTION IV OVERALL SYSTEM THEORY. Provides block diagram and detailed theory of operation of the controller unit and various sections that apply to the overall system.
- SECTION V MAINTENANCE/ALIGNMENTS. Provides board alignment procedures.
- SECTION VI TROUBLESHOOTING. Provides general information for troubleshooting.
- SECTION VII PARTS LIST. Provides a parts list for the entire assembly.

## 1.2 Equipment Description

The following technical manual is intended to familiarize the reader with the Harris Broadcast Amplitude Modulation Companding (AMC+) system for Digital Amplitude Modulation (DX) transmitters. Even though DX transmitters are already highly efficient (overall 83% or better), AMC+ may be used to further reduce operating costs. AMC+ may also be referred to as Dynamic Amplitude Modulation.

AMC+ may already be installed in the transmitter or be delivered as a field upgrade kit.

### 1.2.1 AMC+ Concept

AMC+, which stands for Amplitude Modulation Companding, is a method of Adaptive Carrier Control (ACC). Harris Broadcast offers two methods of Adaptive Carrier Control, ACC+ and AMC+. The AMC+ concept is very simple, however, in understanding the operation and benefits of AMC+, it may be easier to first consider a transmitter's typical modulation scheme and the ACC+ method. To illustrate how power savings is achieved, without either ACC+ or AMC+ carrier control, regardless if the audio input is increased or decreased, the carrier power of a normally modulated transmitter will remain at full output. For example, if the transmitter's audio input is reduced and modulation is only 50%, then carrier power is wasted. The ACC+ method decreases the carrier power during low levels of input audio (modulation), thus resulting in power savings.

Where AMC+ differs from ACC+, an AMC+ enabled transmitter provides full carrier power during periods of no audio, and reduces the transmitter's carrier power with increases in audio input and/or modulation. Both methods result in power savings, however, AMC+ allows for power savings while the transmitter is modulated, thus providing full carrier power during periods of no audio.

For example, with AMC+ and no audio, carrier is full power. Since AMC+ reduces the carrier power starting at 10% modulation until 100% modulation, starting at 10% modulation, as the transmitter is modulated to 100%, the carrier level is also reduced to 3 dB, or half power.

In theory, AMC+, dependent upon the time constant of the receiver's AGC and the program material, decreases the possibility of a slight increase in the noise floor of the receiver during periods of low modulation levels (as the receiver's AGC opens up).

Therefore, AMC+ is a form of carrier control that is dependent upon the audio input level and designed to reduce operating costs.

EAMC+ is a carrier reduction curve similar in direction and reduction to AMC+, used when a higher carrier power from the transmitter is desired. EAMC+ allows for a +1.76 dB increase in normal full carrier with no audio present. See figure 1-1 for details.

### 1•2•1•1 Graphical Representation

Refer to the graph (fig. 1-1) in this section.

- a. The horizontal axis displays Audio Input (in dBm) with respect to 100% modulation. On the extreme right side of the scale 0dBm = the audio input level that creates 100% modulation. Typically this level is +10dBm.
- b. The vertical axis displays Carrier Level (in dB) with respect to normal carrier. On the extreme top side of the scale is full carrier at +3dB.
- c. For a normal DX transmitter in AMC mode, the operation would be described by a single straight line at 0dB. 0dB equals 0% modulation and full carrier level.
- d. The other line on this graph represents EAMC+.

The amount of carrier reduction is fixed at -3 dB, corresponding with the set of horizontal lines in the center of the graph.

The point at which AMC+ starts is 10% to 100% modulation. This corresponds with the set of downward-sloping lines towards the right-hand side of the graph.

The carrier level versus audio level is then described by this single function. The user can select the EAMC+ function via jumper-enabled remote command input, which duplicates the AMC+ function, but at a higher level.

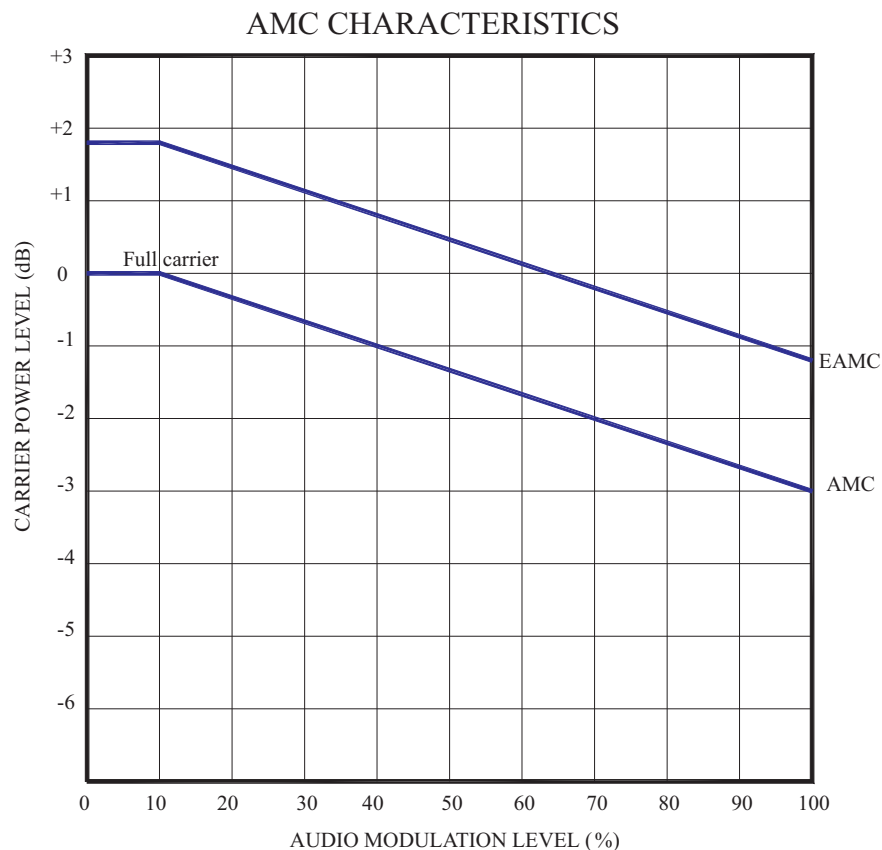

Figure 1-1 AMC+ Characteristics Curve Graph



---

## 1•2•1•2 Power Savings

---

Due to the highly dynamic nature of typical programming, it is difficult to predict actual power savings. However, some stations have performed AMC+ tests on transmitters and reported as much as a 35% savings in power consumption over a non-AMC+ transmitter with no perceptible difference in audio quality or reception range.

## 1•2•1•3 Conclusion

---

AMC+ represents improved ways to reduce energy consumption and reduce operating cost. It can be used with our already highly efficient DX transmitters without effecting listener pleasure or disturbing coverage area.

## 1.3 Block Diagram

---

The AMC+ system is contained on a PC board that is mounted inside the transmitter. Program audio is applied to the AMC+ board and then connected to the transmitter audio input. A carrier sample from the oscillator is required for synchronization of the system. The power supplied required by the AMC+ circuit board is supplied by the transmitters internal power supplies.

## 1.4 Specifications

---

The following is a listing of the specifications for this unit.

### 1.4.1 Reduction Accuracy

---

Accuracy: +/-0.5dB carrier reduction accuracy when properly aligned.

### 1.4.2 Squarewave Overshoot

---

With AMC+ enabled, 3% maximum.

### 1.4.3 AMC+ Operation

---

AMC+ On/Off selectable by local toggle switch or by ground sink remote control.

### 1.4.4 Audio Input Level

---

Normally +10 dBm for 100% modulation.

### 1.4.5 Audio Input Impedance

---

Balanced input with selectable 600 ohm or high impedance.

### 1.4.6 Audio Input Connector

---

Terminal strip TB1.

 **Note**  
*Specifications subject to change without notice.*

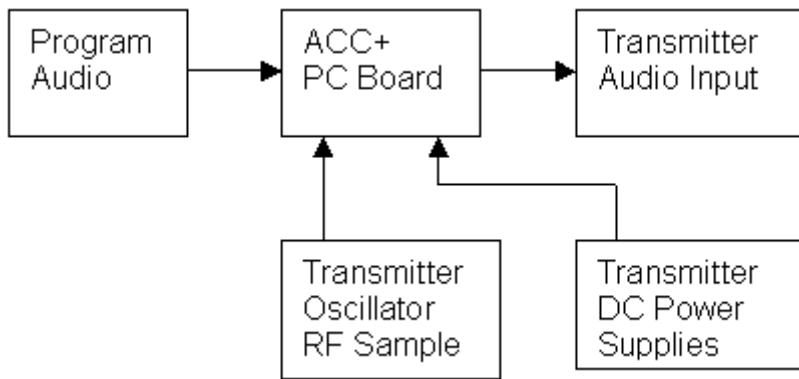

Figure 1-2 Simple Block Diagram of the AMC+ System

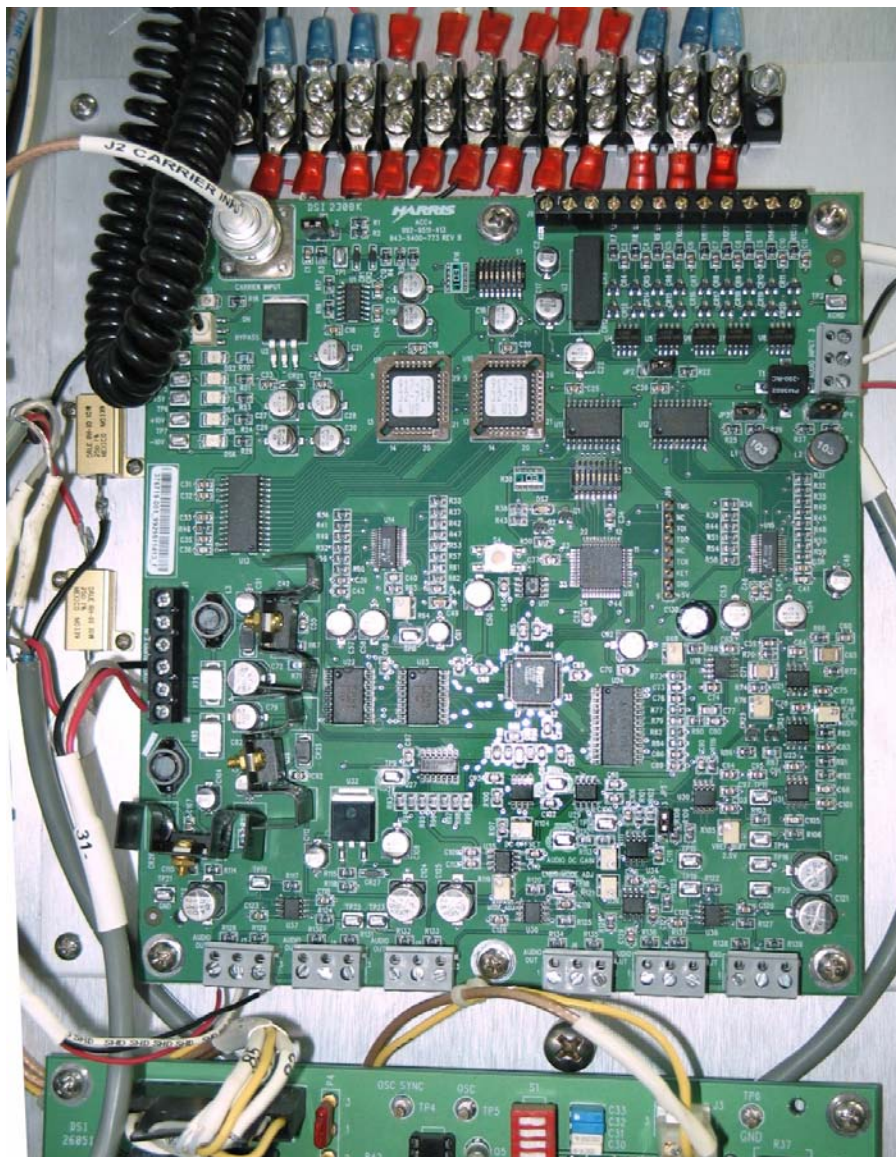

Figure 1-3 AMC+ Board Installed in DX-10

# 2 Section-2 Installation

---

## 2.1 Introduction

This section provides information and instructions necessary for the installation and initial turn-on of the AMC+ Amplitude Modulation Companding board in a DX-10, DX-15, DX-25U, and DX-50.

## 2.2 Returns And Exchanges

Damaged or undamaged equipment should not be returned unless a written Return Authorization is issued. When communicating with Harris Broadcast, specify the order number or invoice number. Include complete details regarding circumstances and reasons for return in the request. Custom equipment or special order equipment is not returnable. In instances where return or exchange of equipment is at the request or convenience of the customer, a restocking fee will be charged. Special shipping instructions and coding will be provided to insure proper handling. All returns will be sent freight prepaid and properly insured by the customer.

## 2.3 Unpacking

If AMC+ is not already installed in the transmitter, carefully unpack the unit and save all packing material. Inspect thoroughly for any damage incurred in shipment. Retain all PACKING CHECK LISTS (if provided) to locate and identify any components or assemblies removed for shipping.

## 2.4 Installation

This section provides the information necessary to install and verify performance of the AMC+ Amplitude Modulation Companding in a DX-10, DX-15, DX-25U, or DX-50 transmitter.



### Note

*See "Figure 3-1 Component Locator" on page 3-2. See Table 6-1 on page 6-2 for a listing of testpoints jumpers LEDs and potentiometers.*

The part number of the AMC+ Installation Kit for the DX transmitter is 992-9764-443. The AMC+ installation kit contains:

- a. AMC+ PC board.
- b. Mounting plate with mounting hardware and terminal strip
- c. Audio cables and lugs
- d. DC power cable
- e. RF sync cable
- f. (2) 25Ω 10W resistors
- g. Adjustment tools
- h. ACC+ Audio Connection (**Interconnect**) drawing #843-5523-792 Rev G or later

### 2.4.1 Test Equipment Needed for Installation

The following test equipment is needed to install the AMC+ circuit and verify its performance:

- a. Audio generator
- b. Oscilloscope or modulation monitor
- c. Spectrum analyzer (optional)

## 2.4.2 Transmitter Configuration and Alignment

---



### Note

Refer to the Transmitter's Technical Manual and Drawing Package for the following procedure.

- a. On the Analog Input board ensure wire 100 is going to J1 for 600  $\Omega$  audio input impedance.
- b. Turn the transmitter ON at HIGH power and make the following adjustments:
  - 1. Raise HIGH power level to the desired power level.
  - 2. Switch to MEDIUM power and raise power level to the desired power level.
  - 3. Switch to LOW power and raise power level to the desired power level.
- c. Apply audio at +10 dBm and adjust R15 Audio Gain potentiometer on the **Analog Input** board for 100% modulation.
- d. Turn the transmitter OFF and **turn off the low voltage AC circuit breakers CB1 and CB2.**

## 2.4.3 Mechanical Installation and Audio Connections

---



### Note

You may have to reposition the tool holders originally located just above the Oscillator board.

- a. Carefully remove the plastic tool holder.
- b. Remove any remaining adhesive.
- c. Place the supplied plastic tool holders as shown in picture to the right (This is showing the LED board on the inside of the center PA cabinet door of a DX-10).

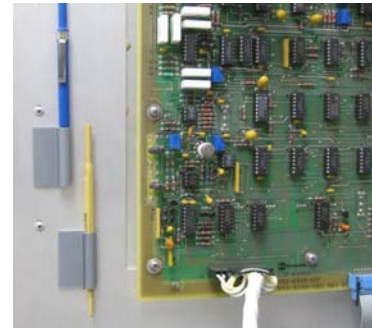

### 2•4•3•1 Mount Resistors

---

Secure the 2 resistors with the hardware provided as shown in Figure 2-1 on page 2-3. Solder the black and red wires in place according to the *Interconnect* diagram.

### 2•4•3•2 Mount AMC+ Board

---

- a. Using the mounting plate as a template, mark the four outside corners and mounting holes. Drill holes as necessary, based upon connector size.
- b. Attach mounting plate to transmitter's center compartment right side wall, just above Oscillator board.
- c. Attach AMC+ board and terminal strip to mounting plate standoffs with hardware provided.

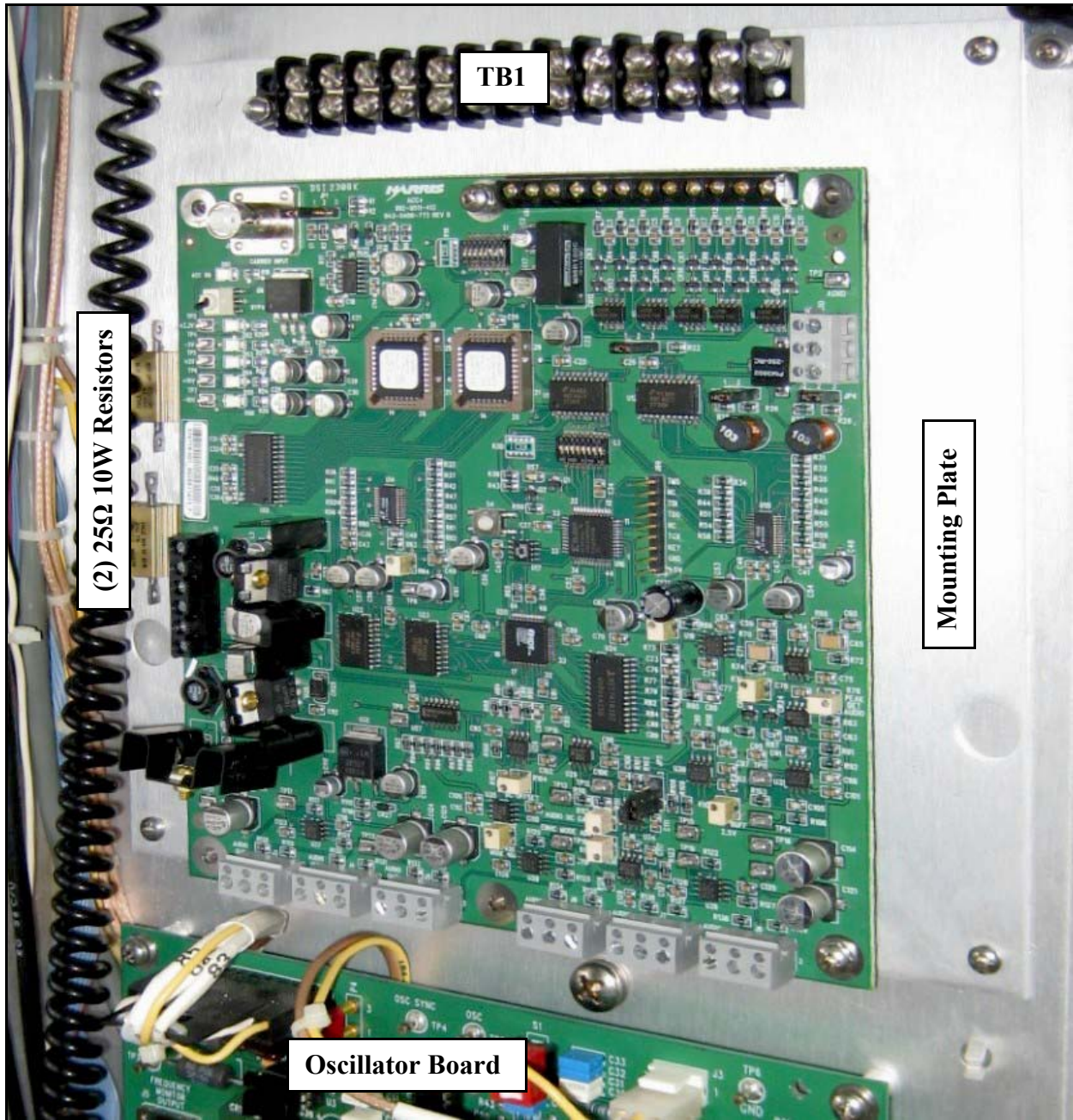

**Figure 2-1**  
AMC+ Board on Mounting Plate in DX10, Showing Location of the Resistors and TB1

2•4•3•3    Make Audio, RF and Voltage Connections



**Caution**

*DISCONNECT PRIMARY POWER BEFORE ACCESSING THE RECTIFIER COMPARTMENT.*

- a. Disconnect primary power.
- b. Open the front Rectifier compartment panel and locate Power Distribution board.

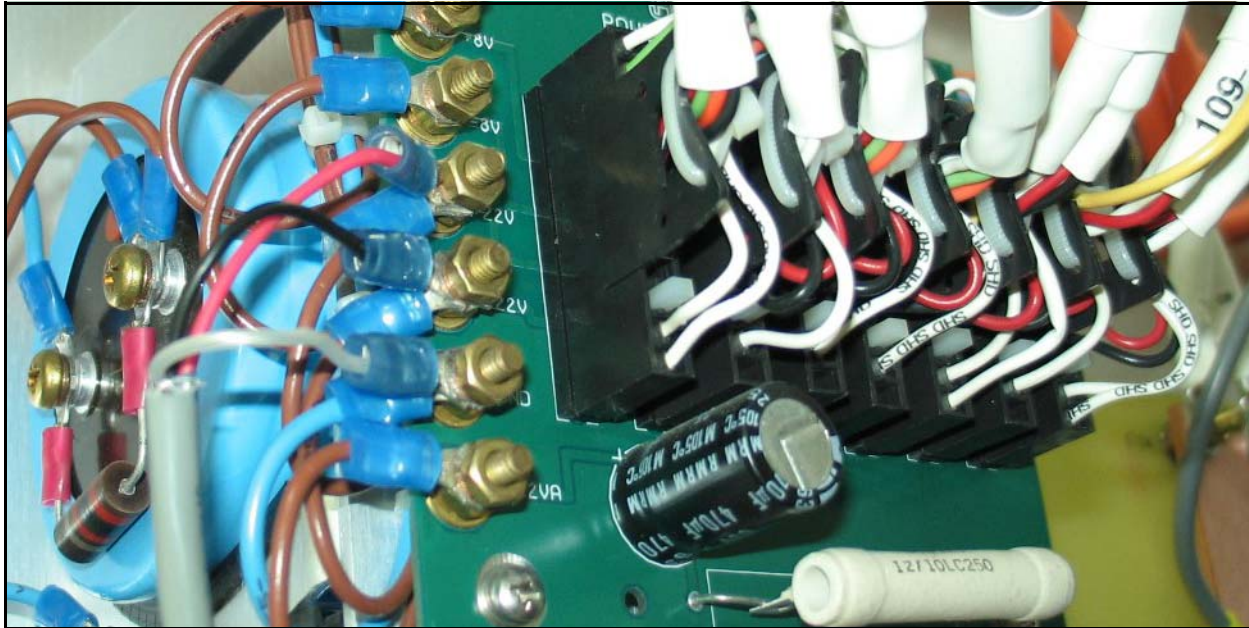

**Figure 2-2**  
**Power Distribution Board of DX-10**  
(Located on the Upper Left Hand Sidewall of Rectifier Compartment)



**Note**

Refer to *Interconnect Diagram 843-5523-792 Rev G* or later, and the *Component Locator* at Figure 3-1 on page 3-2, for the following connections:

- c. Using the 3-conductor cable #33, connect the **red wire lug** to **+22V** terminal; **black wire lug** to the **-22V** terminal; and the **clear wire lug** to **GND**.
- d. Run the loose end of the cable through the hole grommet in the sidewall above the AMC+ board, and connect to corresponding TB1 terminals.
- e. Connect the **red** and **black** wire lugs of  **cable #32** from corresponding TB1 terminals to **R1/R2**. Solder wires at resistors.
- f. Connect the **red** and **black** wire lugs of  **cable #31** from **R1/R2** to the corresponding VDC inputs of the AMC+ board.



**Caution**

**BE SURE TO MAINTAIN POSITIVE (+) AND NEGATIVE (-) VOLTAGE POLARITY CONTINUITY IN STEPS "C" THROUGH "F".**

- g. Connect clear-jacketed wire of  **cable #31** to the clear-jacketed wire of  **cable #32**. Solder and wrap protectively.
- h. Reconnect primary power but **leave circuit breakers CB1 and CB2 off**.
- i. Using the supplied coax cable kit, connect between the **AMC+ Carrier Input** BNC jack (J2) and the **Oscillator** board Frequency Monitor Output BNC jack (J5).
- j. Using the 2-conductor (plus shield) audio  **cable #30**, connect audio input to the **External Interface** board running the audio cable through the channel above the door.
- k. Connect this audio  **cable #30** to the corresponding TB1 terminals, according to Interconnect Diagram.

- l. Connect **cable #29** from TB1 to TB1, accordingly.
- m. Make AMC+ *Audio In* cable **#27** connection between the corresponding TB1 terminals and **J10** of ACC+ bd.
- n. Make AMC+ *Audio Out* cable **#28** connection between the corresponding TB1 terminals and **J3** of ACC+ bd.
- o. Connect customer audio in from processor/STL to terminals 1, 2, & 3 of TB1.

 **Note**

*Be sure to maintain maintain positive (+) and negative (-) audio polarity throughout steps "j" through "o".*

- p. Loop, tie up, and secure any loose or extra cable lengths.

### 2.4.4 Analog Input Board Modifications

- a. Remove the **Analog Input** board from Transmitter.
- b. Solder a jumper across C6 and C7, and also across R28. This allows DC level input for AMC+ operation.
- c. Reinstall the **Analog Input** board into the Transmitter.

## 2.5 Initial Settings After Installation

- a. Turn circuit breakers CB1and CB2 back on.
- b. On the **Analog Input** board adjust R27 Maximum Power fully counter clock-wise.
- c. *Ensure AMC+ is turned off or bypassed, with switch S2 (Switch is down, DS1 is off).*

### 2.5.1 Select AMC+ Phase Delay (S3)

For optimum AMC+ performance, the audio must be delayed by 1mS on this board. With dual channel oscilloscope probes on TP8 and TP12, you can verify the delay of 1mS after the following switch settings have been made, *and the CPLD has been reset.*

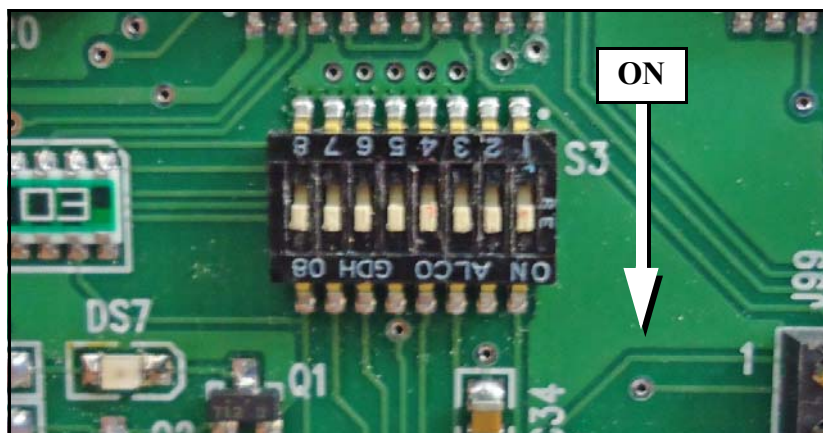

**Figure 2-3**  
**S3 Shown With All Switches Closed (zero/ON)**

 **Note**

*0 means the switch is closed, or in the ON position (switch is in the DOWN position when viewed with the BNC connector at the top left corner as installed).*  
*1 means the switch is open or in the OFF position (switch is in the UP position when viewed with the BNC connector at the top left corner as installed).*

Using the dipswitch weighting listing *below*, divide each by your carrier frequency to determine the individual delays for each position. Then determine which switches will need to be enabled to provide the total 1mS delay for your carrier frequency.

- S3- 1 = 8192
- S3- 2 = 4096
- S3- 3 = 2048
- S3- 4 = 1024
- S3- 5 = 512
- S3- 6 = 256
- S3- 7 = 128
- S3- 8 = 64



**Note**

*The CPLD must be reset in order for the changes of S3 to become active. To do this, press S4 on the AMC+ board after you change the settings of S3.*

**Example:**

Using the table below that was created based on a carrier frequency of 1089kHz, the added delays of switches #4 and #8 create a total delay of 0.999mS. This is the closest value, to 1mS, attainable with this switch configuration.



**Note**

*It is better to be slightly over 1mS, than under.*

**Table 2-1 Example Phase Delay Chart**

| S3 | Weighting | Carrier Frequency | Delay (mS) |
|----|-----------|-------------------|------------|
| 1  | 8192      | 1089000           | 7.522      |
| 2  | 4096      | 1089000           | 3.761      |
| 3  | 2048      | 1089000           | 1.881      |
| 4  | 1024      | 1089000           | 0.940      |
| 5  | 512       | 1089000           | 0.470      |
| 6  | 256       | 1089000           | 0.235      |
| 7  | 128       | 1089000           | 0.118      |
| 8  | 64        | 1089000           | 0.059      |

## 2.6 AMC+ Setup for DX Transmitters

This section provides alignment information for the ACC+, Adaptive Carrier Control board, with AMC+ (Amplitude Modulation Companding) version IC's U9 and U10, Part Number 917-2332-719.

The AMC+ board is aligned in the factory, however it will require field adjustment for frequency selection. Also, in the event the AMC+ board requires replacement, this section is intended to provide guidance to establish AMC+ board level alignment.



**Note**

*See the Component Locator Figure 3-1 on page 3-2, to help locate potentiometers and testpoints for the procedures below.*

- a. Connect audio input and audio output to/from the audio generator.
- b. Jumper settings are; JP1: 1-2, JP2:1-2, JP3:1-2, JP4:1-2, JP5: 2-3.



- c. Connect carrier input and terminate for 50 Ohms input, input level is 1Vrms to 3Vrms.
- d. Set audio generator output level to 10dBm for 600 Ohms, audio frequency @ 1kHz. Turn output on.
- e. Turn transmitter low voltage on.
- f. Verify dipswitch S3 is set according to procedure in "2.5.1 Select AMC+ Phase Delay (S3)" on page 2-5 (On is "0")
- g. Set dipswitch S1-1 through S1-8 to 0000000 (On is "0")
- h. Insure S2 set to ACC mode OFF (Switch is DOWN, DS1 is off).
  - i. Monitor TP16 with an oscilloscope and adjust R76 until the peak to peak voltage is 7.60V.
  - j. Monitor TP8 with an oscilloscope and adjust R64 until the peak to peak voltage is 1V.
  - k. Monitor TP12 with an oscilloscope and adjust R68 until the peak to peak voltage is 6.0V.
  - l. Monitor TP11 with a digital voltmeter (with negative on chassis ground) and adjust R78 for  $5.0 \pm 0.02V$ .
- m. Adjust R119 fully counter clockwise.
- n. Adjust R121 fully clockwise.
- o. Using an oscilloscope, set a zero volt DC reference on the display and monitor TP20. With the scope probe DC coupled, adjust R105 until the bottom of the sine wave touches the zero reference level on the scope. It may be helpful to amplify the signal on the scope for ease of adjustment.
- p. While monitoring TP20 with an oscilloscope, adjust R113 until the peak to peak voltage is 2.5V.
- q. Switch S2 to ACC mode ON (Switch is UP, DS1 is on)
- r. While monitoring TP20 with an oscilloscope, adjust R104 until the bottom of the sine wave touches the zero reference level on the scope. It may be helpful to amplify the signal on the scope for ease of adjustment.
- s. Adjust R119 clockwise for a peak to peak voltage of 2.0V.
- t. Switch S2 to ACC mode OFF (Switch is DOWN, DS1 is off).
- u. Turn transmitter on and slowly raise power control to maximum while insuring transmitter does not *exceed* desired power level.



### Note

*If the transmitter attains the desired output, and still has excess raise control, it will be necessary to reduce the carrier using R113 (adjust counter clockwise).*

- v. Use R105 and R113 and make a final trim to produce the desired power level and 100% modulation exactly.



### Note

*R105 and R113 interact.*

*R105 counter clockwise causes carrier level to decrease and modulation to increase, while clockwise causes carrier level to increase and modulation to decrease.*

*R113 counter clockwise causes carrier level to decrease, and clockwise causes carrier level to increase, while having no significant effect on modulation.*

- w. Switch S2 to ACC mode ON (Switch is UP, DS1 is on)
- x. Use R104 and R119 to match half (3dB power reduction) of desired power level and 100% modulation exactly.



### Note

*R104 and R119 interact.*

*R104 counter clockwise causes carrier level to decrease and modulation to increase, while clockwise causes carrier level to increase and modulation to decrease.*

*R119 counter clockwise causes carrier level to decrease, and clockwise causes carrier level to increase, while having no significant effect on modulation.*

- y. Remove modulation and ensure full desired output power. Minor re-adjustment to R104 and R119 to satisfy both the conditions of; with 10 dBm audio, and without audio are satisfied.

- z. As a final step, using program modulation, toggle between ACC ON and OFF while observing negative modulation. Turn R104 slightly (for example, counter clockwise will decrease the modulation level but will also increase the carrier level), then adjust R119 (for example, counter clockwise to lower the carrier level) back to the desired power level.



**Note**

*To aide in final alignment.*

*The following list is a description of what mode and the affect adjusting the 4 most important potentiometers have on carrier level and modulation.*

- **ACC OFF**  
**R105 DC Offset:**  
CCW causes Carrier level to decrease and Modulation level to increase  
CW causes Carrier level to increase and Modulation level to decrease
- **ACC Operate Mode**  
**R104 DC Offset:**  
CCW causes Carrier level to decrease and Modulation level to increase  
CW causes Carrier level to increase and Modulation level to decrease
- **ACC Operate Mode**  
**R119 Audio+DC Trim**  
CCW causes carrier level to decrease  
CW causes carrier level to increase
- **ACC ON or OFF (normally aligned with ACC OFF)**  
**R113 Audio+DC Gain:**  
CCW causes Carrier level to decrease  
CW causes Carrier level to increase

This concludes the Alignment of the AMC+ board and it is now ready for verification in a DX transmitter.

### 2.6.1 Initial Turn On

- a. Turn transmitter on HIGH.
- b. Turn AMC+ on with S2 on the AMC+ board (Switch is up, DS1 is on).

### 2.6.2 AMC+ Verification

The table below is a quick check for proper AMC+ operation with transmitter ON at the desired power of 10kW:

**Table 2-2 AMC+ Operational Check for 10kW Desired Power**

| Audio %   | AMC Bypass (S2) | AMC On (S2) |
|-----------|-----------------|-------------|
| 0%        | 10kW            | 10kW        |
| 100%      | 10kW            | 5kW         |
| 0% → 100% | 10kW            | 10kW → 5kW  |

Further verifying AMC+ is shown below.

- a. Using an oscilloscope and the transmitter’s forward power meter; or using a spectrum analyzer and modulation monitor connect the transmitter modulation monitor sample to the equipment described above.
- b. Turn on the program modulation, and record the level of carrier reduction and percentage of modulation.
- c. Verify that the forward power of the transmitter is reduced accordingly with the percentage of modulation (See Figure 1-1 on page 1-3).



**Note**

*Errors in transmitter forward power metering at reduced powers or spectrum analyzer/modulation monitor calibration, may contribute to inaccuracies.*

# 3 Section-3 Operation

---

## 3.1 Introduction

---

This section contains normal operational procedures and information pertaining to the function of the AMC+ Amplitude Modulation Companding.

## 3.2 Operation

---

This operational procedure is presented under the assumption that the controller has been properly installed and checked out as outlined in Section II, Installation/Initial Turn-On, of this manual.

- a. Normal AMC+ Bypass and AMC+ On operation
- b. Identification of all panel controls and indicators

### 3.2.1 AMC+ Bypass

---

With the transmitter turned on, and **ACC On/Bypass** switch (S2) set to BYPASS, the forward power meter should show the power level selected and not change significantly with modulation.

### 3.2.2 AMC+ On

---

With the transmitter turned on and AMC+ is on (**ACC On/Bypass** switch, S2, set to ON), it is normal to see the carrier power level fluctuate with modulation, and DS1 indicator (**ACC On**) will be illuminated amber (yellow). The amount of carrier power level fluctuation will be determined by the modulation (see Table 2-2 on page 2-8).

### 3.2.3 Controls and Indicators

---

Figure 3-1, below, shows the following components' location:

- ON/BYPASS switch S2 (upper left corner of board)
- ON/BYPASS indicator DS1 (upper left corner of board)
- S1 Curve selection
- S3 Phase Delay selection
- J10 Audio Input connector
- JP3 and JP4 Audio Input Impedance selector
- J2 Carrier Input connector
- JP1 Carrier Input Termination selector
- All potentiometers
- J9 Remote Control connector
- J3 - J8 Audio Output connectors
- J1 DC Power Input connector
- DC Power Supply connectors

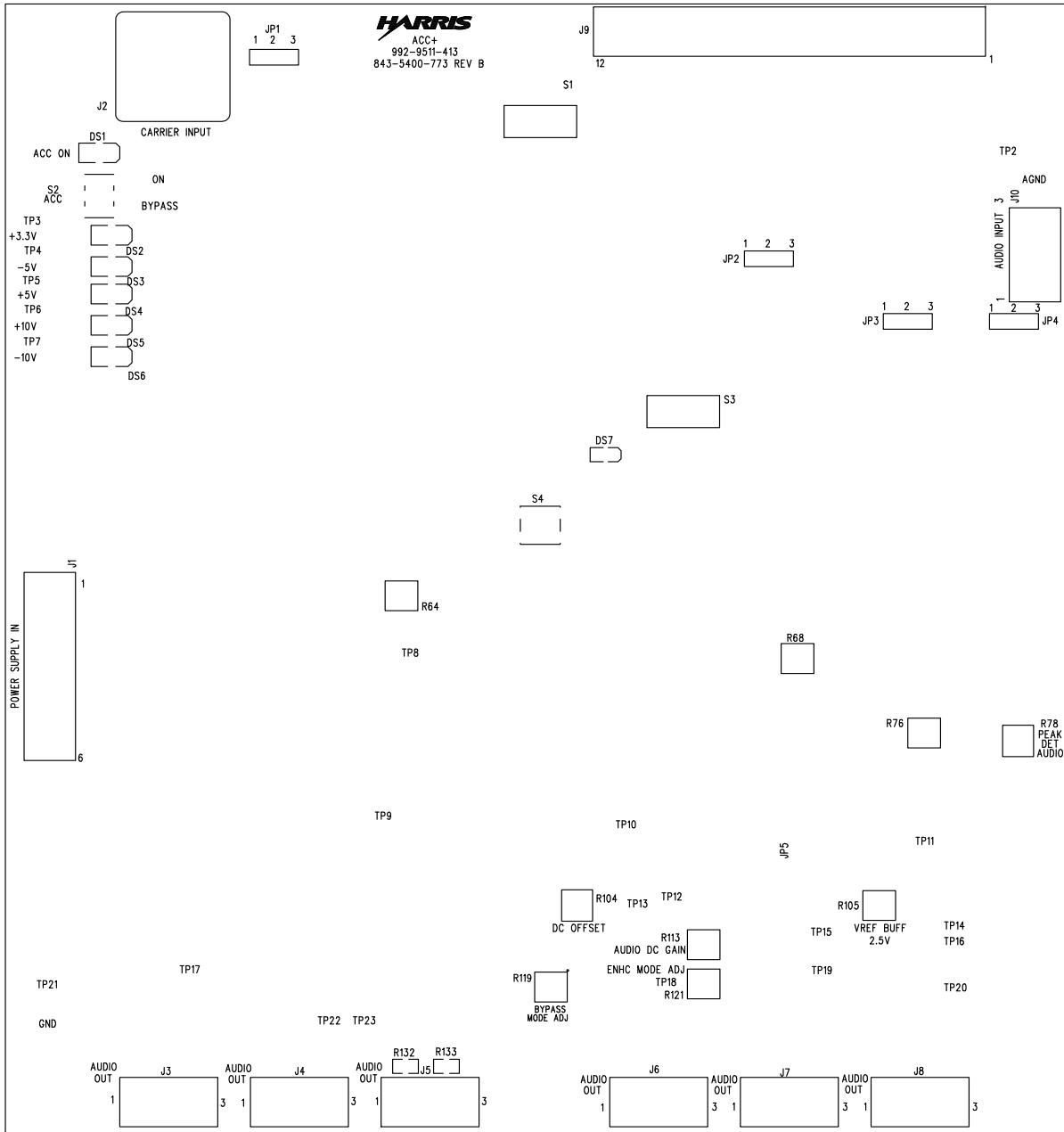

**Figure 3-1  
 Component Locator**

# 4 Section-4 Theory

---

## 4.1 Introduction

This section presents the the circuit description of the AMC+ Amplitude Modulation Companding. Refer to Figure 4-1 Block Diagram and Figure 6-1 on page 6-3, Simplified Schematic.

### 4.1.1 AMC+ OFF Mode of Operation

The AMC+ mode can be turned OFF by putting S2 in the bypass position. When this is in bypass, the carrier control feature is disabled and the output power of the transmitter will remain steady at the selected power level. DS1 will not be illuminated.

### 4.1.2 AMC+ ON Mode of Operation

The AMC+ mode can be turned ON by putting S2 in the ACC-ON position. When this mode is ON, the carrier control feature is active and the output power of the transmitter will fluctuate with the % of modulation. DS1 will be illuminated amber.

---

## 4.2 Detailed Circuit Description

Refer to the schematic, 843-5400-771 in the back of this technical manual for the following discussion.

### 4.2.1 Audio Input

Audio input is connected to J10:

|       |         |
|-------|---------|
| J10-1 | + Audio |
| J10-2 | Ground  |
| J10-3 | - Audio |

The input audio signal is filtered and buffered through a low pass filter and differential op-amp U21. Audio input impedance is selected by JP3 and JP4:

|                   |                  |
|-------------------|------------------|
| JP3 1-2 & JP4 1-2 | = 600 Ohms       |
| JP3 2-3 & JP4 2-3 | = high impedance |

The buffered audio signal is then scaled and peak detected, with a fast attack and slow decade peak detector circuit consisting of U25 and U31.

### 4.2.2 A/D Converter - Look Up Table

The DC level at TP14 is varying according to the audio input level. The peak-detected voltage is converted to a 12-bit digital data by the A/D converter (U16). The 12-bit word is then addressed to the pre-stored Look-Up-Table (LUT) content in the memory devices (U10, U9). The output of the LUT also has 12-bits of resolution.

### 4.2.3 D/A Converter

The 12-bit data from the LUT is then converted to transmitter's carrier level by the D/A converter (U13). The output is then adjusted by the DC offset control R104 and applied to switch U28.

---

## 4.2.4 Phase Delay

---

The non-sampled audio coming from U21 is fed into a A/D Converter (U14). The Digital out is then fed into a High Speed CMOS D-Type Flip Flop. The outputs of this drive a CPLD where, depending on the S3 settings, it will determine the amount of delay. The output of the CPLD is then fed to a D/A converter. The Output of the D/A then goes thru a DC blocking cap (C130) and then U15. R68 provides the DC Offset. This DC carrier level from U15 and the delayed audio signal are then summed through the opamp U30, with gain adjustment control from R113. This Audio + DC output is then applied to the audio driver.

## 4.2.5 Carrier Synchronization

---

All digital circuits are operating synchronously, all of the clock pins are tied to the transmitter's carrier frequency for best performance and minimized inter-modulation products.

A carrier RF sample is obtained by a sample from the Oscillator board. JP1 is normally set 1-2 for a 50 Ohm termination.

## 4.2.6 Remote Control

---

The AMC+ board is capable of remote and local selection; it can be programmed with 12-bit dynamic resolution.

J9 is the remote control connection. Remote control selection is activated by ground sync connection and buffered by opto isolator U4. Connecting the appropriate J9 connector to ground will activate the function. When local AMC ON/OFF switch S2 is ON (AMC ON), J9-9 is the command input (active low) that enables or disables the AMC (or EAMC) mode. J9-8 is the command input (active low) that enables the Enhanced AMC mode (EAMC).

*NOTE: JP2 must be set to 1-2 in order to enable this command.*

## 4.2.7 Audio+DC Output Driver

---

The Audio+DC output is then connected to the transmitter's normal audio input through the Audio Driver.

The Audio Driver stage is fanned out to 6 outputs at J3 through J8. Each audio signal pair is buffered by a set of differential driver op-amps. For single transmitter configurations, J3 is typically used:

|      |         |
|------|---------|
| J3-1 | + Audio |
| J3-2 | Ground  |
| J3-3 | - Audio |

## 4.2.8 Power Supplies

---

Board DC power is normally supplied from the existing DC supplies within the transmitter. Typically a +VDC from the transmitter cabinet's Power Distribution board will be connected to J1-4, and a -VDC will be connected to J1-6.

These supplies are regulated to +10, -10, +5, -5 and +3.3 VDC on the AMC+ board by regulators U1 through U4 and U9. Test points and indicators are provided near the edge of the board as troubleshooting aids.

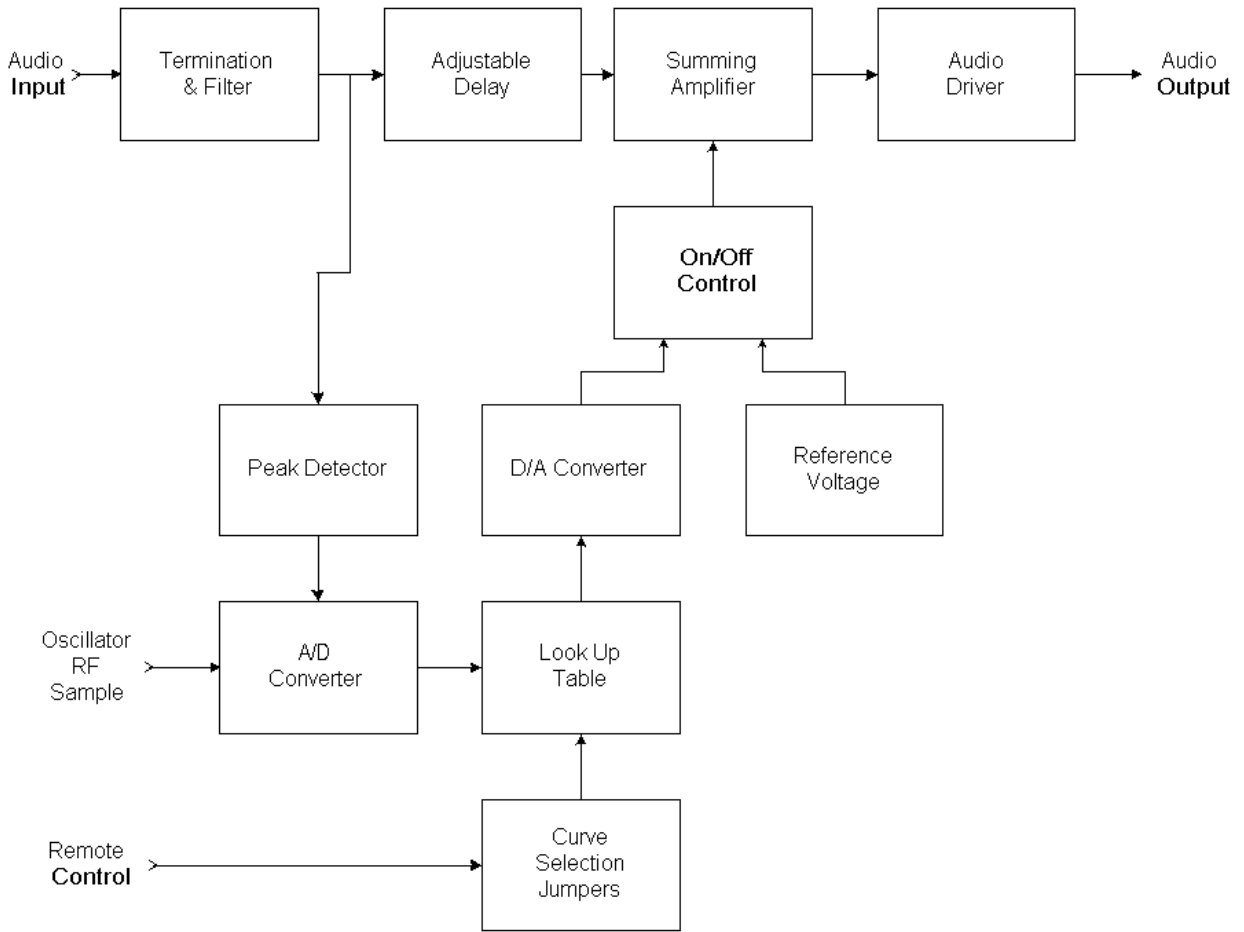

**Figure 4-1**  
**AMC+ Block Diagram**





# 5 Section-5 Maintenance

---

## 5.1 Introduction

---

This section provides alignment information for the ACC+, Adaptive Carrier Control board, with AMC+ (Amplitude Modulation Companding) version IC's U9 and U10, Part Number 917-2332-719.

## 5.2 Purpose

---

The AMC+ board is aligned in the factory, however it will require field adjustment for frequency selection. Also, in the event the AMC+ board requires replacement, this section is intended to provide guidance to establish AMC+ board level alignment.

## 5.3 AMC+ Phase Delay (S3)

---

See "2.5.1 Select AMC+ Phase Delay (S3)" on page 2-5 for this complete procedure.

## 5.4 AMC+ Alignment for DX Transmitters

---

See "2.6 AMC+ Setup for DX Transmitters" on page 2-6 for this complete procedure.

## 5.5 AMC+ Verification Procedure

---

See " This concludes the Alignment of the AMC+ board and it is now ready for verification in a DX transmitter." on page 2-8 for this complete procedure.



# 6 Section-6 Troubleshooting

---

## 6.1 Introduction

Troubleshooting of AMC+ consists of reading this manual and verifying proper installation and alignment. The following can be used as a guide. See Table 6-1 on page 6-2 for a listing of testpoints, jumpers, LEDs, and potentiometers.

## 6.2 Troubleshooting Hierarchy

### 6.2.1 Power Supplies

Verify power supplies are present at J1-4 and J1-6, and observe power supply indicators DS2-DS6.

### 6.2.2 Carrier Sync

Verify Oscillator sample at TP9. A 5Vp-p square wave at carrier frequency should be present.

### 6.2.3 Jumper Settings

Verify jumper settings are as described in sections 2 and 4 of this manual.

### 6.2.4 Audio Input/Output

Use an oscilloscope to verify correct audio signal at AMC+ input, J10. Also check for an audio output signal at J3.

## 6.3 ACC bypass mode

Refer to the AMC+ schematic for jumper arrangements when bypassing the AMC+ function.

In addition to moving the jumper wire to bypass the function the Analog Input (or Audio Input) board in the transmitter must be adjusted.

Refer to the Analog Input board schematic in the transmitter drawing package for specific jumper and potentiometer numbers. Also refer to the transmitter instruction book for the set up procedure of the board.

First the Analog Input board will have to be AC coupled by moving jumpers that were in DC couple mode when using the AMC+ board. The Audio Gain adjustment and Max Power Adjustment will need to be set up with the AMC+ in bypass mode.

## 6.4 Component Table

The following table displays important testpoints jumpers LEDs and potentiometers.

**Table 6-1 Pertinent Testpoints, Jumpers, LEDs, & Potentiometers**

| Test Point | LED (DS) or Jumper | Pot. | Name / Function                        | Comment / Value                                                    |
|------------|--------------------|------|----------------------------------------|--------------------------------------------------------------------|
|            | DS1                |      | AMC+ On                                | Illuminates when AMC+ is Enabled                                   |
|            | DS7                |      | Reset                                  |                                                                    |
| TP1        |                    |      | Carrier Input                          |                                                                    |
| TP2        |                    |      | GND A                                  |                                                                    |
| TP3        | DS2                |      | +3.3Vdc                                |                                                                    |
| TP4        | DS3                |      | -5Vdc                                  |                                                                    |
| TP5        | DS4                |      | +5Vdc                                  |                                                                    |
| TP6        | DS5                |      | +12.7Vdc                               |                                                                    |
| TP7        | DS6                |      | -12.7Vdc                               |                                                                    |
| TP8        |                    | R64  | Non-Sampled Audio                      | 1.0 - 1.2Vp-p                                                      |
| TP9        |                    |      | 0.5V P-P                               |                                                                    |
| TP10       |                    |      | Audio DC Offset                        |                                                                    |
| TP11       |                    | R78  | Audio                                  | +5.0Vdc ±0.02Vdc                                                   |
| TP12       |                    | R68  | Delayed Audio                          | 6.93 - 7.2Vp-p                                                     |
| TP13       |                    |      |                                        |                                                                    |
| TP14       |                    |      | Peak Detected Audio                    |                                                                    |
| TP15       |                    |      | V Rdf Buffer 2.5Vdc                    |                                                                    |
| TP16       |                    | R76  | Audio                                  | +7.6Vdc                                                            |
| TP17       |                    |      | Audio Outputs                          |                                                                    |
| TP18       |                    |      | Audio Outputs                          |                                                                    |
| TP19       |                    |      | Audio Outputs                          |                                                                    |
| TP20       |                    | R104 | Audio Outputs                          | 3.0Vp-p on zero reference                                          |
| TP21       |                    |      | GND                                    |                                                                    |
| TP22       |                    |      | Audio Outputs                          |                                                                    |
| TP23       |                    |      | Audio Outputs                          |                                                                    |
|            |                    | R105 |                                        | VREF Buffer 2.5Vdc (Non-ACC Carrier Level Adjust)                  |
|            |                    | R113 |                                        | Audio+DC Gain Adjust                                               |
|            |                    | R119 |                                        | ACC On Audio+DC Gain Adjust                                        |
|            |                    | R121 |                                        | Enhanced Mode Adjust                                               |
|            | JP1                |      | Carrier Input Impedance Select         | 1-2: 50Ω Carrier Input<br>2-3: High Impedance Carrier Input        |
|            | JP2                |      | Remote Activation of Enhanced Mode     | 2-3: Enables Remote Activation of Enhanced Mode                    |
|            | JP3                |      | Audio Input Impedance Select           | 1-2: 600Ω Audio Input Impedance<br>2-3: High Audio Input Impedance |
|            | JP4                |      | Audio Input Impedance Select           | 1-2: 600Ω Audio Input Impedance<br>2-3: High Audio Input Impedance |
|            | JP5                |      | Inverted or Non-Inverted Peak Detector | 1-2: Positive Audio Detection<br>2-3: Negative Audio Detection     |

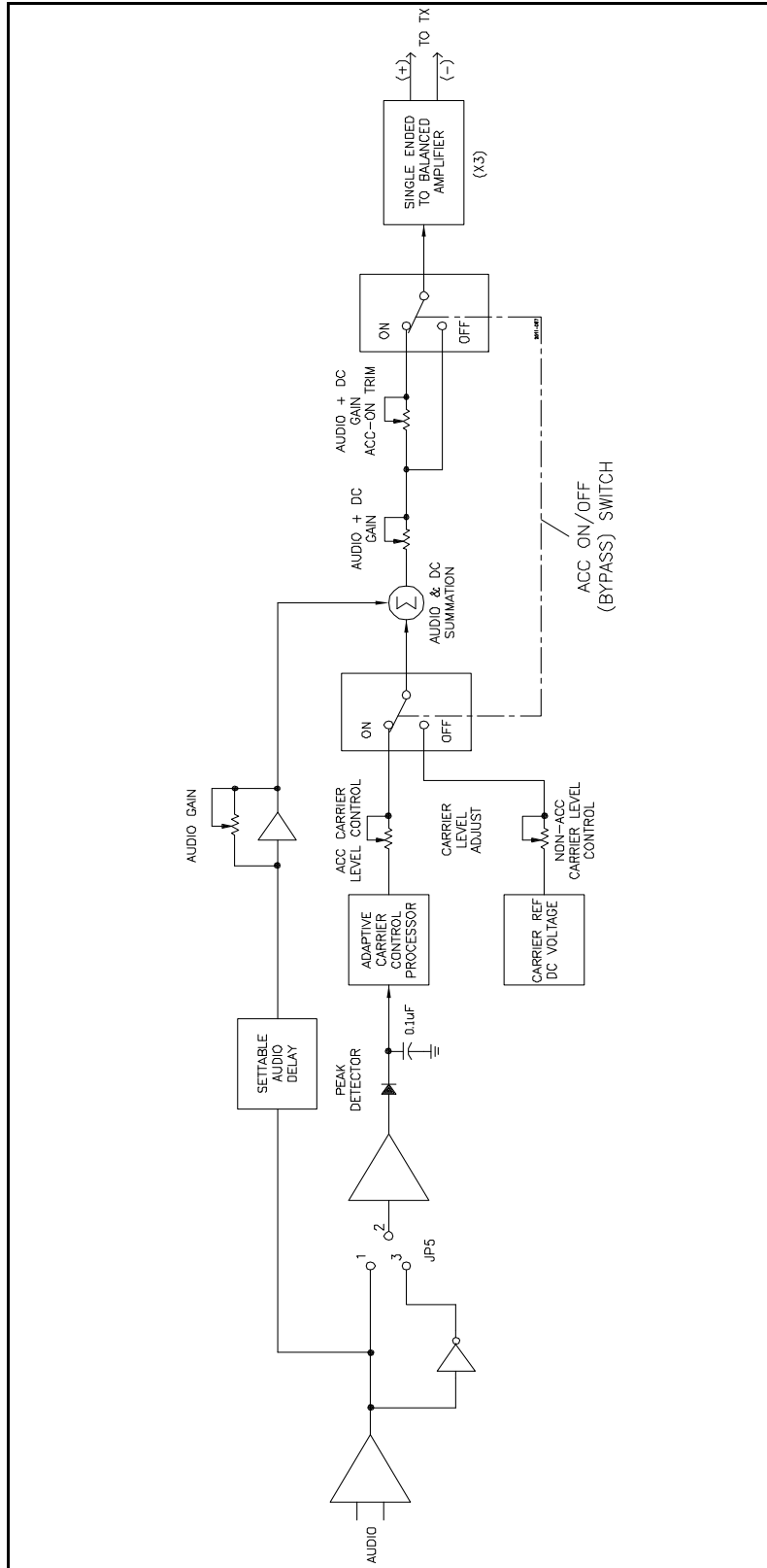

Figure 6-1 Simplified Schematic



# 7 Section-7 Parts List

## 7.1 Parts List

|           |                        |                    |     |
|-----------|------------------------|--------------------|-----|
| Table 7-1 | ACC+ KIT, LOW POWER AM | 992 9764 443 ((A)) | 7-1 |
| Table 7-2 | AMC+ BOARD             | 992 9764 320 (A)   | 7-1 |
| Table 7-3 | PWA, ACC+              | 992 9511 413 (F)   | 7-1 |

**Table 7-1 ACC+ KIT, LOW POWER AM - 992 9764 443 ((A))**

| Part Number  | Description                      | Qty UM | Ref Des |
|--------------|----------------------------------|--------|---------|
| 464 0349 000 | TOOL, ADJUSTMENT                 | 2 EA   |         |
| 542 1735 000 | RES 25 OHM 1% 10W                | 2 EA   |         |
| 614 0505 000 | TERM BD 12 TERM                  | 1 EA   |         |
| 843 5523 792 | ACC+ AUDIO CONNECTION DIAGRAM DX | 0 DWG  |         |
| 917 2332 772 | CABLE, RF ACC+ INTERCONNECT      | 1 EA   |         |
| 917 2332 773 | CABLE PKG, ACC+ INTERCONNECT     | 1 EA   |         |
| 939 8220 414 | PANEL, ACC MOUNTING              | 1 EA   |         |
| 992 9764 320 | AMC+ BOARD                       | 1 EA   |         |

**Table 7-2 AMC+ BOARD - 992 9764 320 (A)**

| Part Number  | Description    | Qty UM | Ref Des |
|--------------|----------------|--------|---------|
| 917 2332 719 | FIRMWARE, AMC+ | 1 EA   | U9 U10  |
| 992 9511 413 | PWA, ACC+      | 1 EA   |         |

**Table 7-3 PWA, ACC+ - 992 9511 413 (F)**

| Part Number  | Description                       | Qty UM | Ref Des                  |
|--------------|-----------------------------------|--------|--------------------------|
| 404 0908 000 | *HEATSINK, VERTICAL, TO-220       | 3 EA   | XU18 XU26 XU33           |
| 522 0588 000 | CAP 100UF 25V 20% 8MM NON-POLAR   | 1 EA   | C130                     |
| 610 1069 000 | HDR, 9C 1ROW VERTICAL UNSHR       | 1 EA   | J99                      |
| 612 1184 000 | JUMPER SHUNT, 2C, 0.1" PITCH      | 5 EA   | XJP1 XJP2 XJP3 XJP4 XJP5 |
| 646 2110 000 | BARCODE, SN_ITEM_REV              | 1 EA   |                          |
| 817 2551 014 | PROGRAMMING INSTR, ACC/DELAY      | 0 DWG  | #U16                     |
| 614 0953 005 | *TERMINAL STRIP, 6 TERM           | 1 EA   | J1                       |
| 620 1677 000 | JACK, BNC STRAIGHT PCB            | 1 EA   | J2                       |
| 614 0909 000 | TERM BLK, PCB, 3-POLE, GREY (237) | 7 EA   | J3 J4 J5 J6 J7 J8 J10    |
| 614 0953 006 | *TERMINAL STRIP, 12 TERM          | 1 EA   | J9                       |
| 610 0900 000 | HDR, 3C VERT 1ROW UNSHR           | 5 EA   | JP1 JP2 JP3 JP4 JP5      |
| 492 0881 000 | CHOKE, 10MH 20% 89MA RADIAL       | 2 EA   | L1 L2                    |
| 382 1633 000 | IC, LT1033 ESD                    | 1 EA   | U33                      |
| 382 1328 000 | IC, 1085 ESD                      | 1 EA   | U18                      |
| 382 0184 000 | *IC, LM340A/LM7805AC (TO-220)     | 1 EA   | U26                      |
| 566 0037 000 | CONVERTER, DC/DC 5V .75W ESD      | 1 EA   | U3                       |
| 992 9511 414 | PWA, ACC+ SMT                     | 1 EA   |                          |
| 843 5400 771 | SCH, ACC+                         | 0 DWG  |                          |







Support Contacts: <http://harrisbroadcast.com/support>  
eCustomer Portal: <http://support.harrisbroadcast.com>

Trademarks and tradenames are the property of their respective companies.



9800 S Meridian Blvd | Ste 300 | Englewood, CO 80112 U.S.A.  
©2013 Harris Broadcast  
Harris Broadcast is an independent company not affiliated with Harris Corporation